

301738

CHROME TAPPET BLOCK COVER SET FOR 1986 THRU 1990 EVOLUTION SPORTSTER MODELS

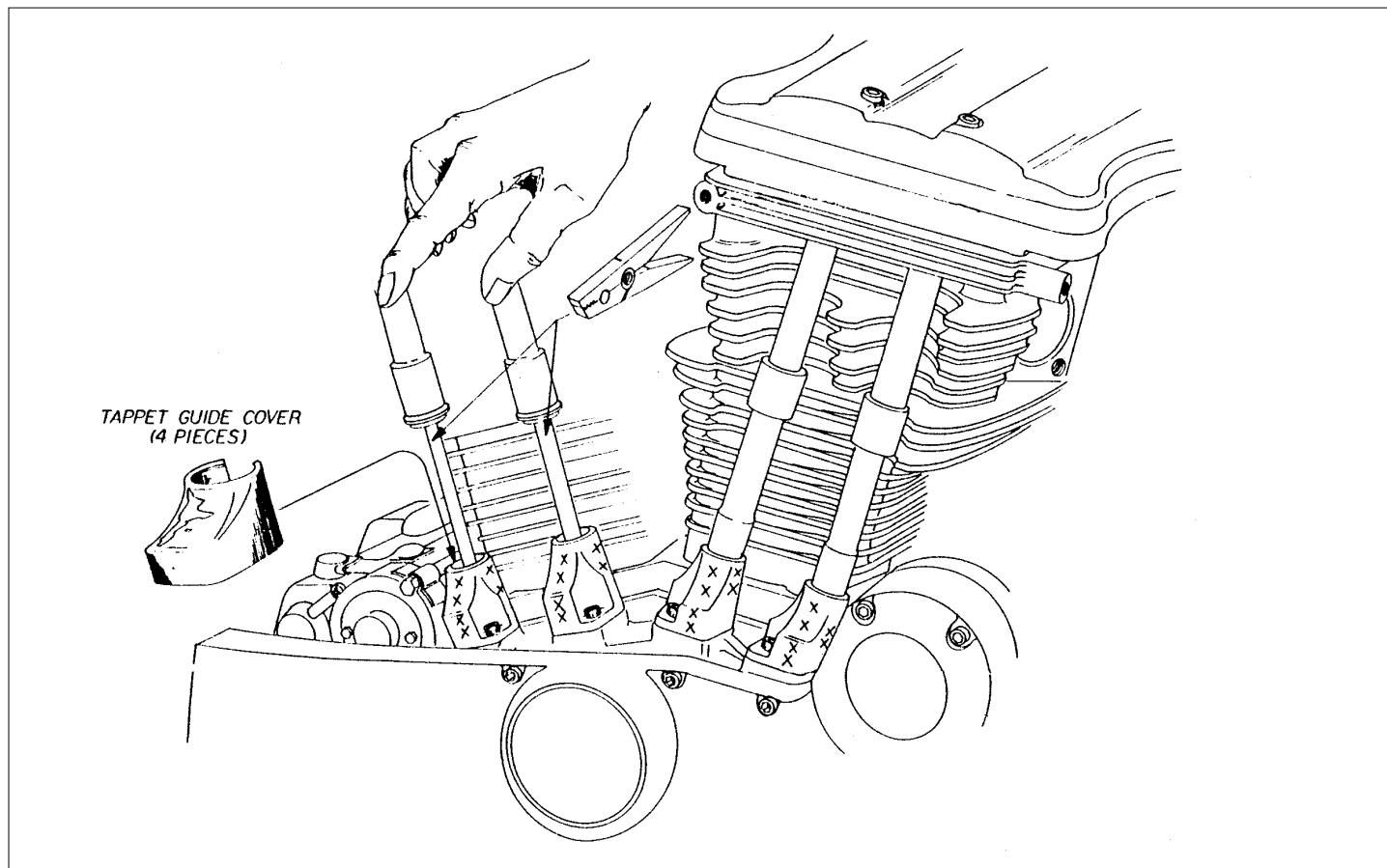

1. Installation must be performed on a cold engine. We recommend installing these covers in the evening, permitting the silicone adhesive used in step 5 to cure overnight before engine start-up.
2. Clean outside of tappet guides and pushrod tubes to remove any oil, dirt, or grease using degreaser. Allow to dry completely.
3. Remove air cleaner to permit easy access to pushrod tubes.
4. Remove all four pushrod tube retaining clips and raise the pushrod tubes a few inches above the tappet blocks. We recommend using four spring-type clothes pins to hold tubes up, out of the way. Any oil which leaks onto the tappet guides must be cleaned completely away.
5. Using silicone adhesive provided, put smooth, even 1/4"-long beads on the tappet guides where illustrated with an "XX". Do not use an excess, only a small amount is required.
6. Carefully install covers by sliding cover slot around pushrods. Gently push both covers down onto tappet guides as far as possible.
7. Pass pushrod tubes into tappet guides, through cover openings. Reinstall tube clips and check for a good tube seal.
8. Clean away any excess silicone that may have squeezed out during installation.
9. Reinstall air cleaner assembly.
10. Allow motorcycle to sit cold for 12 hours (overnight) to permit silicone to cure before start up.